

CAPILLARY FLOW OF HEALING AGENTS IN DISCRETE CRACKS IN CEMENTITIOUS MATERIALS

Diane R Gardner¹, Andrea Hoffman¹ and Anthony D. Jefferson¹

¹Cardiff University, Cardiff School of Engineering, Queen's Buildings, The Parade, Cardiff, CF24 3AA. UK.

Email: GardnerDR@cf.ac.uk

Keywords: Self-healing, Capillary flow, Mortar, Discrete cracks

ABSTRACT

In the UK 43% of all costs associated with the construction industry are spent on structural repair and maintenance [1] and a significant proportion of this may be attributed directly to the nation's ageing concrete civil infrastructure. Cracks present in concrete structures, as a result of shrinkage or mechanical loading, may lead to the promotion of deterioration processes such as freeze-thaw action, chloride ingress or carbonation. Capillary absorption, driven primarily by surface tension has been frequently noted in the literature as one of the primary transport mechanisms by which aggressive agents from the environment ingress concrete. Conversely, capillary absorption is also the mechanism by which concrete is able to self-heal and work in the area of autogenic and autonomic self-healing cementitious materials [2] has proved promising in enhancing the longevity of structures.

This paper presents an investigation of capillary flow of water and cyanoacrylate in discrete cracks in cementitious materials. A series of capillary rise experiments have been completed using 30 x 30 x 75mm mortar specimens clamped together with spacers to form a range of crack apertures of 0.110 mm to 1.170 mm. Tests have been conducted on 3 different crack configurations; planar, tortuous and natural. The experimental set up is shown in Figure 1. The rate of capillary rise height was captured using a high speed digital camera allowing dynamic contact angles to be observed. The effect of aperture width, mortar age (7 and 28 days), type of healing agent and degree of mortar saturation has been examined.

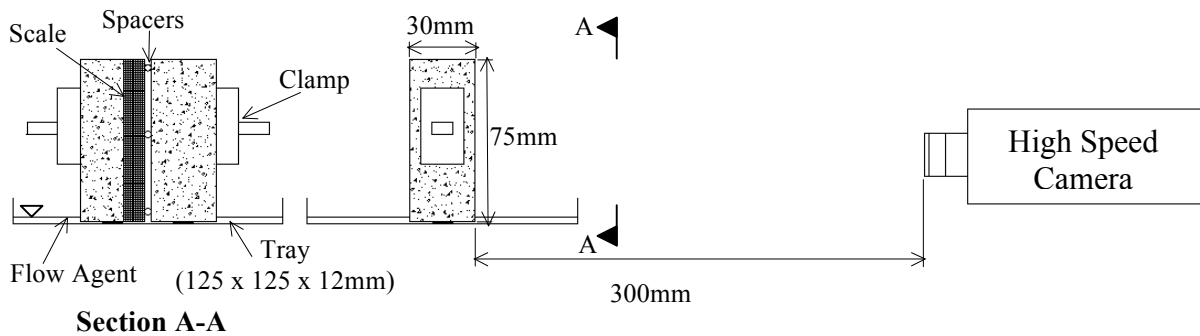

Figure 1: Experimental arrangement for planar crack capillary rise simulation

Results of this investigation showed capillary rise heights increase with decreasing crack aperture in accordance with standard capillary flow theory [3], as given in equation 1.

$$h = \frac{2\gamma \cos \theta}{\rho g r} \quad \text{equation 1}$$

Where h is the capillary rise height (m); γ is the liquid-air surface tension (N/m); $\cos \theta$ is the angle that the meniscus forms with the solid face; ρ is the density of the flow agent (kg/m^3); g is the force due to gravity (m/s^2) and r is the capillary radius (m). In order to compare capillary rise heights predicted

from capillary flow theory for water a contact angle close to zero and surface tension of 0.0728 N/m were assumed.

Capillary rise of water in naturally formed cracks was lower than in planar cracks at the same crack aperture due to larger surface roughness and higher capillary tortuosity of the former, as demonstrated in Figure 2a. Capillary rise height of cyanoacrylate was lower than that of water for crack apertures up to 0.714 mm, due to lower surface tension, differences in contact angle and curing of the cyanoacrylate in the crack plane during the test. The latter observation was more pronounced in the smaller crack apertures due to the smaller mass of glue in the crack plane. The difference in capillary rise heights for water and cyanoacrylate at a range of crack apertures is presented in Figure 2b.

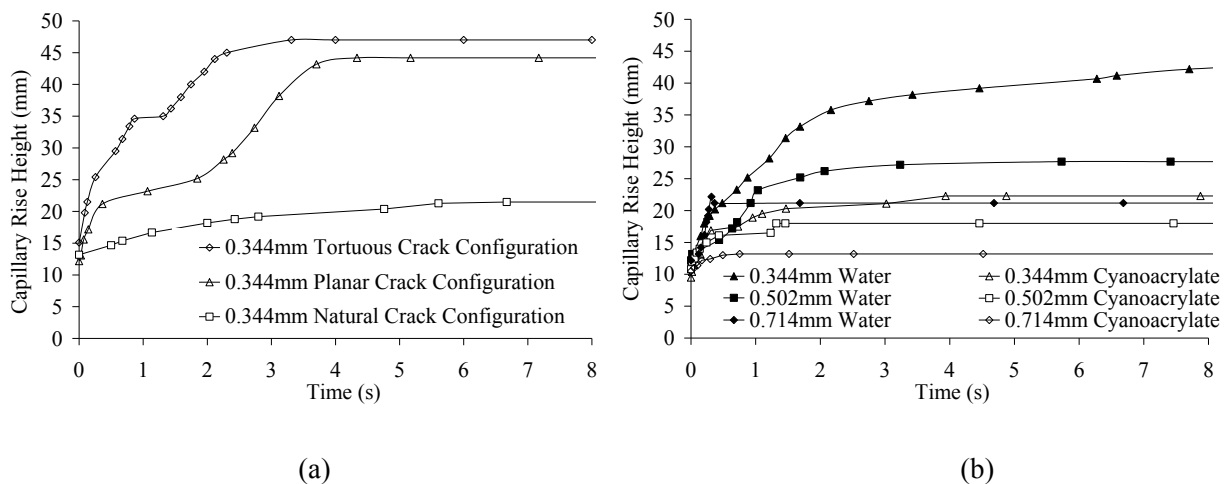

Figure 2: Effect of a) crack configuration on capillary rise height for water at a crack aperture of 0.344mm and b) flow agent in a planar crack on capillary rise height at a range of crack apertures.

Further experiments conducted on mature (28 days or more) and young (less than 7 days old) specimens showed that higher capillary rise heights were obtained for the mature specimens for all flow agents examined. This would suggest that the efficacy of a self healing system, based on final capillary rise heights, would be greater when considered in the long-term. Of equal importance is that no significant differences were observed between final capillary rise heights in saturated and non-saturated specimens, although the rate of capillary rise in saturated specimens was marginally slower.

Preliminary modelling work, which captures capillary rise behaviour in a discrete crack, has also been examined. A 1D finite difference model has been developed for this purpose which is capable of capturing capillary flow in the crack and the retardation of the capillary front during the cyanoacrylate experiments due to the change in flow agent viscosity, as a result of the cyanoacrylate curing during the test.

REFERENCES

- [1] Office for National Statistics. Construction Statistics Annual 2010, 2010, Palgrave Macmillan.
- [2] C. Joseph, D. Gardner, A. Jefferson, R. Lark, and B. Isaacs, Self Healing Cementitious Materials: A review of recent work. *Proceedings of the ICE - Construction Materials*, **164**, 2011, pp. 29 – 41.
- [3] W-B. Young. 2004. Analysis of capillary flows in non-uniform cross-sectional capillaries. *Colloids and Surfaces A: Physicochemical. Engineering Aspects*, **234**, 2004, pp. 123–128.